

Specifications

MODEL		GTH™-4013	
MEASUREMENTS	Metric	US	
Lifting height maximum with outriggers	13.06 m	42 ft 10 in	
Lifting height maximum without outriggers	12.80 m	42 ft	
Lifting capacity maximum	4,000 kg	8,818 lbs	
Lift capacity at maximum height	3,000 kg	6,614 lbs	
Lift capacity at maximum reach	1,250 kg	2,756 lbs	
Forward reach maximum	9.14 m	30 ft	
Reach at maximum height	1.90 m	6 ft 3 in	
A Height	2.46 m	8 ft 1 in	
B Height at steering wheel	1.66 m	5 ft 5 in	
C Width	2.32 m	7 ft 7 in	
D Inside cab width	0.78 m	2 ft 7 in	
E Track	1.92 m	6 ft 4 in	
F Wheelbase	2.95 m	9 ft 8 in	
G Length at front wheels	4.79 m	15 ft 9 in	
H Length at fork-holder plate	6.06 m	19 ft 11 in	
I Ground clearance	0.39 m	1 ft 3 in	
J Overall width, outriggers extended	2.89 m	9 ft 6 in	
M1 Obstruction angle	40°	40°	
M2 Departure angle	46°	46°	

PRODUCTIVITY		
Inside/outside turning radius	2.43 m / 4.65 m	7 ft 11 in / 15 ft 3 in
Break-out force (with 800 L bucket SAE J 732)	6000 kg	13,228 lbs
Drawbar pull*	7,500 kg	12,864 lbs
Drive speed	35 km/h	22 mph
Fork-holder plate rotation	138°	138°
Chassis levelling on front axle	+/- 6°	+/- 6°
Floating forks	L 1200 mm Section 120 x 50 mm	L 3 ft 11 in Section 4.7 in x 2 in
Tyres (DIN 70361)	405/70 24" PR14 8-hole wheel rim	
Lifting/lowering speed**	11 / 9 sec	11 / 9 sec
Extension/retraction speed**	17 / 13 sec	17 / 13 sec

POWER		
Engine	Perkins 1104 D-44T 4-cylinder turbo diesel 74.5 kW (100 hp), Tier 3	
Tank capacities		
Petrol	135 L	35.7 gal
Engine oil	7 L	1.8 gal
Hydraulic oil	150 L	39.6 gal
Hydraulic output /pressure	95 L/min - 270 bar	25 gal/min - 3,916 psi

WEIGHT		
Weight***	10,960 kg	24,163 lbs

STANDARDS COMPLIANCE	AS 1418.19, EN 1459 EU Machinery Directive 98/37/CE Operating cab conforms to ISO3471 (ROPS) and ISO3449 (FOPS) Low emission engine conforms to EU Directive 97/68/EC stage III
----------------------	--

* Maximum load
 ** Without load
 *** Weight will vary depending on options and/or country standards
 **** Load ratings vary depending on attachment

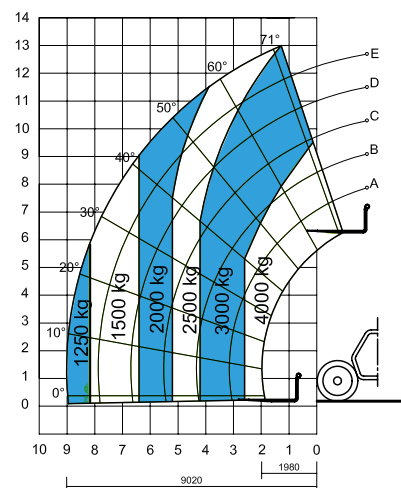
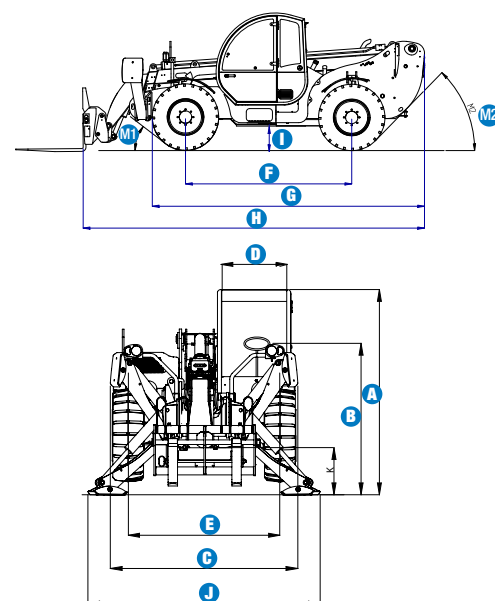

Lift capacity chart (with outriggers)****

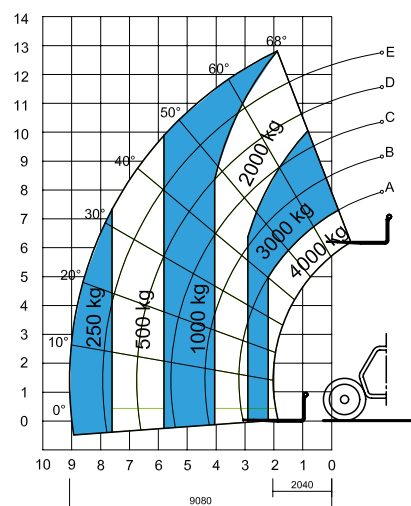

Lift capacity chart (without outriggers)****

EN1459, Annex B

Features

STANDARD FEATURES

MEASUREMENTS

- 4,000 kg (8,818 lb) maximum lift capacity
- 13.06 m (42 ft 10 in) maximum lift height
- 9.14 m (30 ft) maximum forward reach

PRODUCTIVITY

- 4WD
- Four wheel steer
- Three steering modes:
 - Front wheel steer
 - Crab steer
 - Coordinated steer
- Hydraulic line on boom
- Rear axle alignment sensor
- Power assisted steering
- Front outriggers
- Hydrostatic transmission with variable displacement pump and motor electronically controlled
- Two-speed mechanical gearbox
- Multifunction electro-proportional joystick
- Limited slip differential on front axle
- Chassis levelling on front axle +/- 6°
- Floating forks
- Quick coupling of attachments from cab
- Two-section door (glass upper/steel lower)
- Angle and length indicators on boom
- Adjustable suspended seat
- Large diameter steering wheel
- Front and rear windscreen wipers
- Sunshield
- Roof protection grid
- Two side rear view mirrors
- Front and rear lights
- Windshield protection grid
- Side mounted engine for easy access to components
- Oil immersed multi-disc brake on both axles
- Lockable fuel tank

STANDARD FEATURES cont.

- Load Management System (LMS) with:
 - Visible display with coloured LEDs
 - Load moment indicator with LEDs
 - Audible alarm
 - Automatic lock-out of boom extension, lifting and lowering
 - Automatic lock-out of outriggers
- Automatic lock-out of rear axle
- Maintenance collar
- Hydraulic inching
- Road/Jobsite switch
- Boom sfatey strut

POWER

- Perkins turbo diesel 74.5 kW (100 hp), Tier 3

TYRES

- 405/70-24" tyres

OPTIONS & ACCESSORIES

PRODUCTIVITY

- Air conditioning
- Additional rear view mirror
- Hydraulic Winch pre-arrangement on boom
- Man-platform / Emergency hydraulic pump pre-arrangement
- Emergency pump kit
- Adjustable spotlight on boom including cable reel and cable bracket
- Adjustable spotlight on cab
- Fish eye rear view mirror in the back
- Water muffler
- Spare wheel
- Foam filled tyre
- Rear wheels alignment sensor
- Pre-arrangement for hydraulic winch
- Pre-arrangement for man-platform
- AM/FM radio with CD player

ATTACHMENT OPTIONS

Genie has a large range of attachments available. Please contact Genie or your nearest Genie telehandler dealer.



Genie Australia – Toll free number 1800 788 633

Brisbane (Head Office)
33 Kimberley Street
Darra QLD 4076

Sydney
74 Glendenning Road
Glendenning NSW 2761

Melbourne
374 Hammond Road
Dandenong VIC 3175

Perth
126 Sheffield Road
Welshpool WA 6106

Genie United States Distributed by:

18340 NE 76th Street
P.O. Box 97030
Redmond, Washington
98073-9730

Effective Date: April 2012. Product specifications and prices are subject to change without notice or obligation. The photographs and/or drawings in this document are for illustrative purposes only. Refer to the appropriate Operators' Manual for instructions on the proper use of this equipment. Failure to follow the Operators Manual when using our equipment or to otherwise act irresponsibly may result in serious injury or death. The only warranty applicable to our equipment is the standard written warranty applicable to the particular product and sale and we make no other warranty, express or implied. Products and services listed may be trademarks, service marks, or trade names of Terex Corporation, Terex South Dakota, Inc., and/or their subsidiaries in the USA and other countries. All rights reserved. Terex is a registered trademark of Terex Corporation in the USA and many other countries. Genie is a registered trademark of Terex South Dakota, Inc. in the USA and many other countries. ©2009 Terex Corporation.